

RAFS300-220W24 AC-DC Converter

Input 85Vac~265Vac, Output 24Vdc/12.5A, Full-Brick Series

Features

- ◆ Full Brick (116.8mm×61.0mm×12.7mm)
- ◆ Output Voltage Adjust Range: $\pm 10\%$ of the rated output voltage
- ◆ Output Short-circuit Protection, hiccup, auto-recovery
- ◆ High Power Factor, High Efficiency, High Stable Voltage Accuracy
- ◆ High efficiency, 90% typ. (230Vac, Full Load)
- ◆ 3000Vac Isolation Voltage
- ◆ Baseplate Temperature $-40\text{ }^{\circ}\text{C}$ to $+100\text{ }^{\circ}\text{C}$
- ◆ OVP, OCP, Over Temperature Protection (OTP): $110\text{ }^{\circ}\text{C}$ typ.
- ◆ 100% burn in
- ◆ Applications: Industrial electronics & control and Rail transit & railway application

Converter **RAFS300-220W24****Contents**

Features.....	1
Outline Diagram	2
Specifications.....	2
Characteristic Curves.....	4
Design Considerations.....	5
Basic Connection.....	5
Recommended Layout.....	6
Input Voltage Range.....	6
Output Voltage Adjust.....	6
Remote Sense.....	7
Over Temperature Protection.....	7
Output Over Voltage Protection.....	8
EMC Consideration	8
Safety Consideration.....	8
Product Installation.....	8
ESD Control.....	9
Delivery Package Information.....	9
Quality Statement	9
Contact Information.....	9

RAFS300-220W24 AC-DC Converter

Input 85Vac~265Vac, Output 24Vdc/12.5A, Full-Brick Series

Outline Diagram

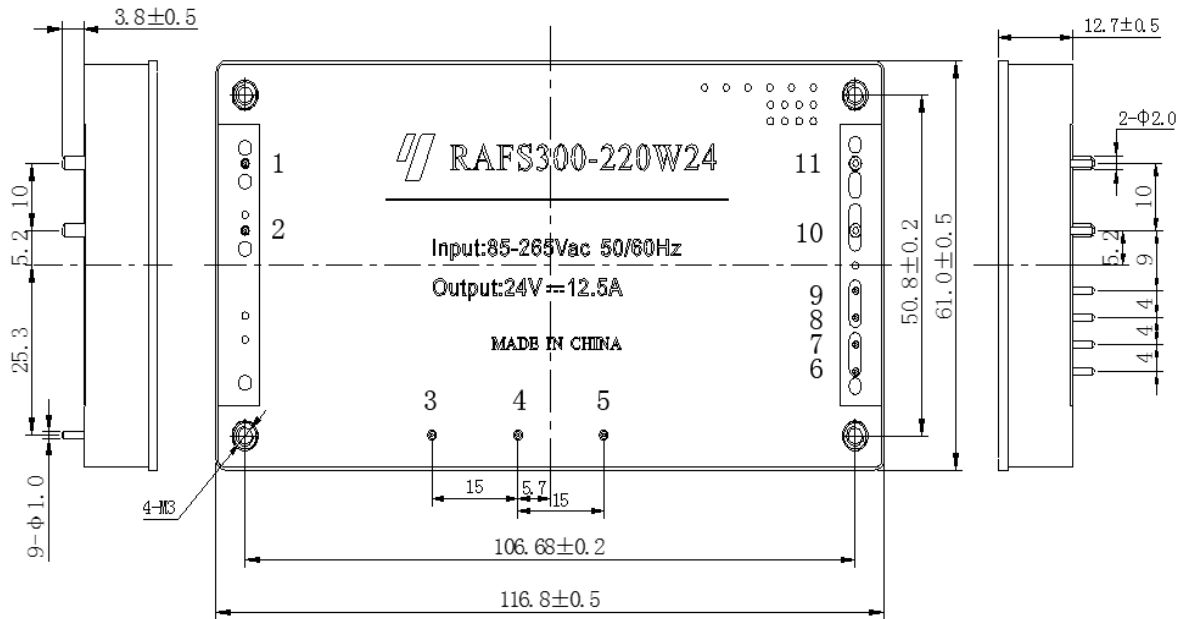

Pin	Symbol	Function
1	AC(N)	AC Input, Neutral Line
2	AC(L)	AC Input, Live Line
3	R	Surge control resistor
4	+BC	PFC Capacitor positive electrode
5	-BC	PFC Capacitor negative electrode
6	NC	No connection
7	TRIM	Output Voltage Adjust
8	+S	Positive Remote Sense
9	-S	Negative Remote Sense
10	+V	Positive Output
11	-V	Negative Output

Case material: black flame retardant Plastic Pin: copper with gold plating
 Aluminum baseplate can be connected to Protective Earth pin by M3 screw.
 Notes:all dimensions in mm(inches)
 Tolerances:X.X±0.5(X.XX±0.02) X.XX±0.25(X.XXX±0.010)

Specifications

Unless otherwise specified, all tests are at room temperature and standard atmosphere, pure resistive load and basic connection.

Input	Symbol	Min	Typ	Max	Unit	Conditions
Input Voltage	V_{in}	85	230	265	Vac	—
Input current	I_{in}	—	—	4.2	A	—
Power Factor	PF	95	—	—	%	—
Input Frequency	f	43	—	63	Hz	—
Input Transient Current	I^2	0	—	50	A	—

RAFS300-220W24 AC-DC Converter

Input 85Vac~265Vac, Output 24Vdc/12.5A, Full-Brick Series

Output	Symbol	Min	Typ	Max	Unit	Conditions
Output Voltage	V_o	23.76	24.00	24.24	Vdc	—
Output Current	$I_{o,nom}$	—	—	12.5	A	—
Output Voltage Adjust Range	V_{trim}	21.6	—	26.4	Vdc	$P_o \leq 300W$, $I_o \leq 12.5A$
Line Regulation	S_V	—	—	± 0.2	$\%V_o$	$V_{in}: 85Vac \sim 265Vac$, $I_o = 12.5A$
Load Regulation	S_I	—	—	± 0.5	$\%V_o$	$V_{in} = 230Vac$, $I_o: 0A \sim 12.5A$
OVP Set Point	$V_{ov,set}$	27.6	—	33.6	Vdc	$I_o = 6A$
Output Overcurrent Protection Set Point	$I_{o,lim}$	13.5	—	15.6	A	—
Output Short-circuit Protection	Hiccup mode, automatic recovery					
Peak to Peak Ripple and Noise	ΔV_{pp}	—	—	280	mV	20MHz bandwidth, four 100 μ F solid electrolytic capacitors should be paralleled at output terminal
Start-up Delay Time	T_{delay}	—	130	—	ms	$V_{in} = 230Vac$
Rise Time	T_{rise}	—	12	—	ms	$I_{o,nom}$, Pure resistive load
Capacitive Load Range	C_O	0	—	2200	μ F	—
Load Transient	Recovery Time	t_{tr}	—	400	μ s	Load change: 25%~50%~25% & 50%~75%~50% Current change: 0.1A/ μ s
	Voltage Deviation	ΔV_{tr}	—	± 1200	mV	

General	Symbol	Min	Typ	Max	Unit	Conditions
Efficiency	η	89	90	—	%	$V_{in} = 230Vac$, $I_{o,nom}$
Switching Frequency	f_s	—	210	—	kHz	—
Isolation Resistance	R_{iso}	100	—	—	M Ω	—
Isolation Voltage	V_{iso}	3000	—	—	Vac	Input to output Leakage current $\leq 10mA$
		2500	—	—	Vac	Input to case Leakage current $\leq 10mA$
		1500	—	—	Vac	Output to case Leakage current $\leq 10mA$
MTBF	—	—	2×10^6	—	h	BELLCORE TR-332
Operating Baseplate Temperature	—	-40	—	100	$^{\circ}C$	—
Storage Temperature	—	-55	—	+125	$^{\circ}C$	—
Temperature Coefficient	S_T	—	—	± 0.02	$\%/^{\circ}C$	—
Over Temperature Protection	T_{ref}	100	110	120	$^{\circ}C$	—
Over Temperature Protection Hysteresis	ΔT_{ref}	—	10	—	$^{\circ}C$	—

RAFS300-220W24 AC-DC Converter

Input 85Vac~265Vac, Output 24Vdc/12.5A, Full-Brick Series

General	Symbol	Min	Typ	Max	Unit	Conditions
Vibration	Sine, Frequency:10Hz-55Hz,Amplitude:0.35mm,30 min in each of 3 perpendicular directions					
Shock	Half sine,peak acceleration:300m/s ² , duration:6 ms ; continuous 6 times of pulse in each of 3 perpendicular directions					
Hand Soldering	Maximum soldering Temperature < 425°C,and duration < 5s					
Wave Soldering	Maximum soldering Temperature < 255°C,and duration < 10s					
Weight	-	-	200	-	g	-

Characteristic Curves

Load Transient Response

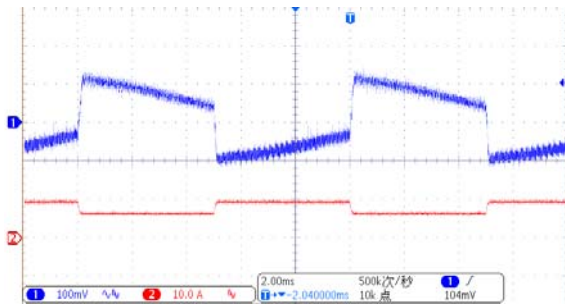

Load change:25%~50%
~25% I_{o,nom}, 0.1A/μs
V_{in}=230Vac
Trace1:100mV/div
Trace2: 10A/div
Time scale: 1ms/div

Load Transient Response

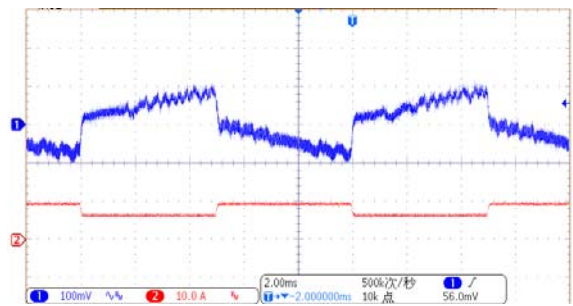

Load change:50~75%
~50% I_{o,nom}, 0.1A/μs
V_{in}=230Vac
Trace1: 100mV/div
Trace2: 10A/div
Time scale: 1ms/div

Output Ripple and noise

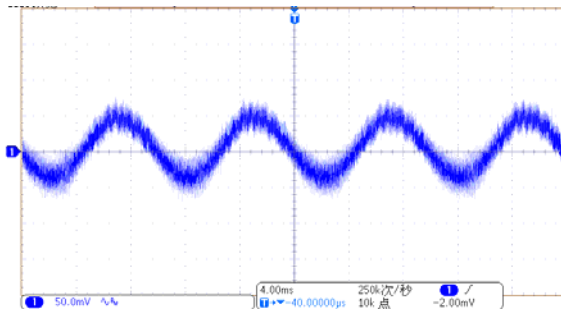

Start-up Delay Time

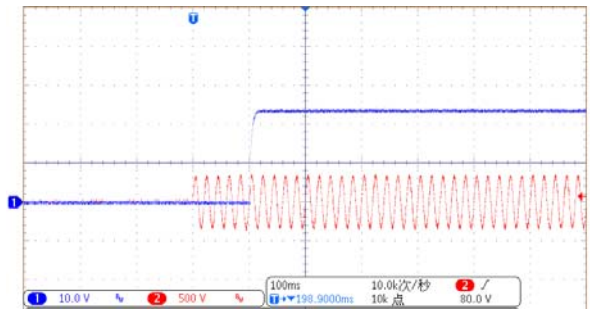

Rise Time

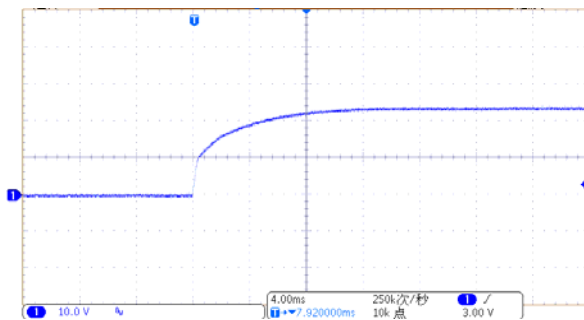

RAFS300-220W24 AC-DC Converter

Input 85Vac~265Vac, Output 24Vdc/12.5A, Full-Brick Series

Efficiency vs Temperature and current

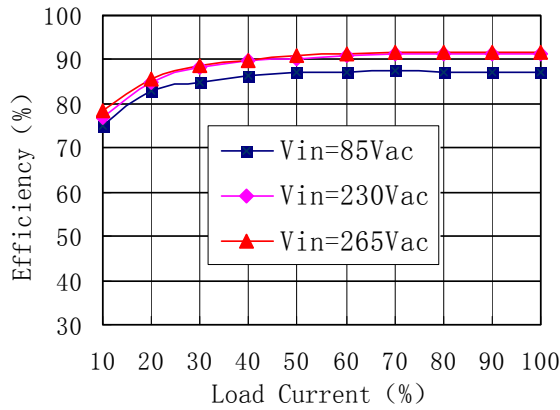

Derating

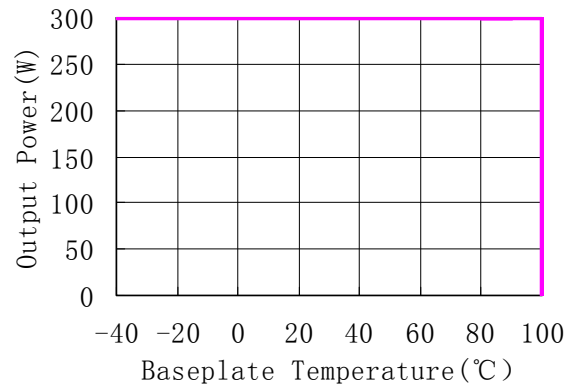

Design Considerations

Basic Connection

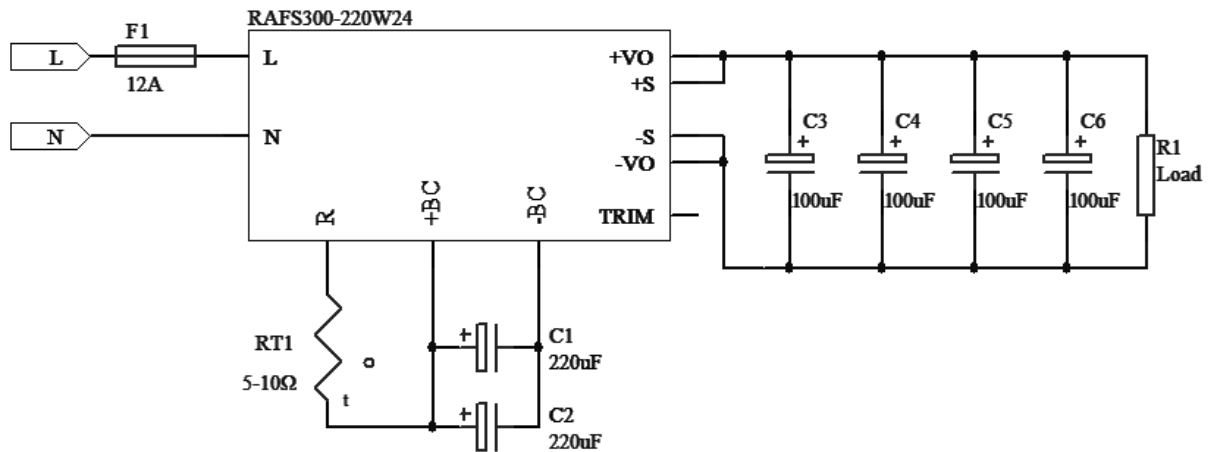

The recommended parameters in the circuit are as follows:

F1: 12A/300W, Slow break safety fuse;

C1\C2: 220µF/450V/-40°C electrolytic capacitor;

RT1: 5~10Ω/≥3W thermistor;

C3\C4\C5\C6: 100µF/35V solid electrolytic capacitors with low ESR when ambient temperature at -40°C;

Notes: When the function of remote sense is not used, the +S pin and +Vo pin should be shorted and the -S pin and -Vo pin should be shorted, too. The basic connection indicates the basic requirements. Please refer to the instruction followed for further information.

RAFS300-220W24 AC-DC Converter

Input 85Vac~265Vac, Output 24Vdc/12.5A, Full-Brick Series

Recommended Layout

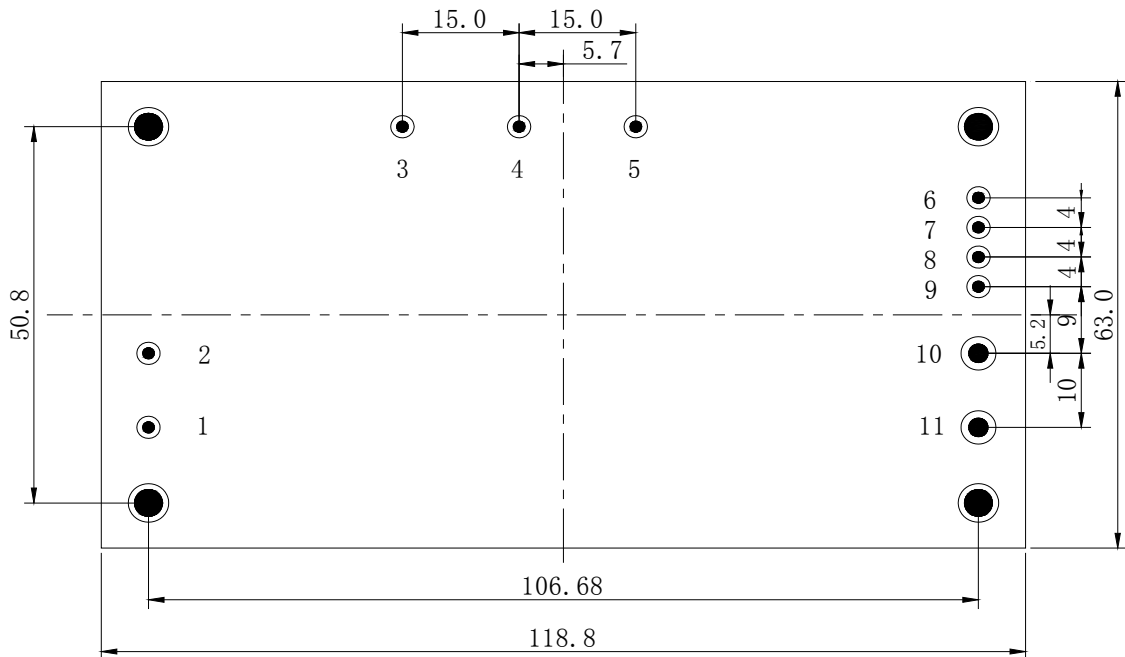

NO.	Recommendation & Notes
Pad Design	1~9 Pad hole diameter is 1.5mm, pad diameter including hole is 3.0mm at least; 10、11 Pad hole diameter is 2.5mm, pad diameter including hole is 4.5mm at least. The fixed holes at the four corners are metallized, with diameter of 3.6mm, pad diameter 5.2 mm within as prohibited wiring area.
Airflow Direction	The air should flow along the direction of the heat sink. perpendicular direction is not recommended.
Safety	Isolated Converters, care to the spacing between input and output, input and protective ground、 output and protective ground.
Electrical	The Vin(-) and Vo(-) planes should be placed under of the converter separately. Avoid routing sensitive signal or high disturbance AC signal under the converter.

Input Voltage Range

The input voltage range of the AC/DC converter is 85Vac~265Vac. The input impedance of the converter looks like a negative resistor, which can interact with the reactance of the power bus (including any filter elements that have been added to the input of the converter), causes an unstable condition.

The method to determine whether the impedance of the power bus too high or not is to decrease the converter's input voltage from higher to lower gradually. Power on the converters with the higher input voltage and normal operation, if the output voltage decreases or unstable sometimes with the lower input voltage, also can restore normal operation after reducing the load current, it will be considered the impedance is too large.

Output Voltage Adjust

The converters have an Output Voltage adjust pin (Trim). This pin can be used to adjust the output voltage above or below Output voltage initial setting. The maximum value of the trimmed up is 10%, Even +S and -S pins are used to compensate the voltage simultaneously, the sum of the trimmed up and the compensation should not be more than 10%, or the characteristics will not be assured in compliant with the specification, even the over voltage protection may be triggered. The output power can not exceed 300W at increased output voltages. and the output current can not exceed 12.5A at decrease output voltages.

RAFS300-220W24 AC-DC Converter

Input 85Vac~265Vac, Output 24Vdc/12.5A, Full-Brick Series

When the trim pins are not used, they should be floated.

External circuit is connected as the figure shown, the resistance is calculated as the formula below, please note that the formula will be invalid when $R_{trim-up}$ 、 $R_{trim-down}$ are used simultaneously, users adjust the value based on the resistance applied.

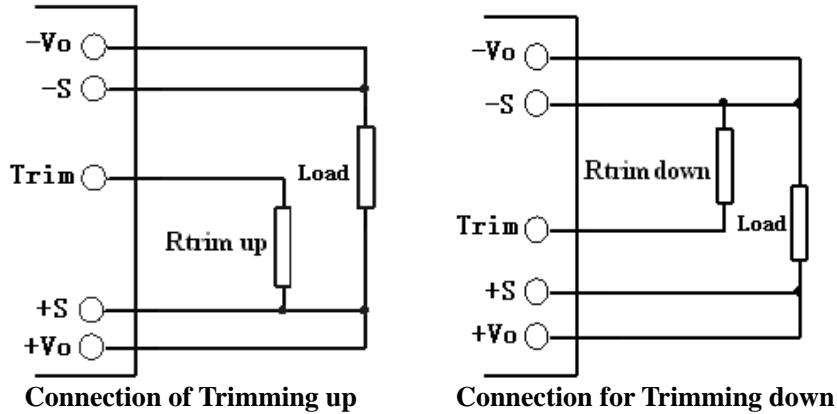

Resistance for trimming up:

$$R_{trim-up} = \left(\frac{5.11 \times V_o(100(\%) + \Delta(\%))}{1.225 \times \Delta(\%)} - \frac{5.11 \times 100(\%)}{\Delta(\%)} - 10.22 \right) (k\Omega)$$

Resistance for trimming down:

$$R_{trim-down} = \left(\frac{5.11 \times 100(\%)}{\Delta(\%)} - 10.22 \right) (k\Omega)$$

V_o : Rated the output voltage you need, This product is 24V;

$R_{trim-up}$ 、 $R_{trim-down}$: Resistance for trimming up or down, kΩ;

ΔV : The output voltage Change (The output voltage you need minus output voltage).

Remote Sense

The remote sense can be used to compensate for the voltage drop between the output pins of the converter and the load input pins by +S、-S pins. The +S and -S pins should be connected to the input pins of the load respectively. The remote sense circuit will compensate for up to 10% voltage drop between the sense voltage and the voltage at the output pins.

The anti-interference design should be considered when the +S、-S pins are connected to the pins to be compensated. The +S、-S traces should be located close to a ground trace or ground plane, and the area they surrounded should be minimized (just for electrical isolation); If cable connection presents, twisted pair wires should be used, EMI core are equipped with the twisted pair wires to reduce common mode noise when necessary, the sense leads should not be longer than 200mm, or the system characteristics may not be assured.

The sense leads only can carry very little current, and are not used for converter power output. Care should be taken in operation to avoid damaging the converter.

Over Temperature Protection

The over temperature protection feature is used to protect the converter, and the sensor locates in the baseplate. If the temperature of the baseplate exceeds the threshold of 100°C, the converter will shut down, The converter will stop until safe operating temperature is restored. Hysteresis temperature between OTP trig point and restart is approx 10°C. Time between OTP and restart is dependent on cooling of DC/DC converter.

RAFS300-220W24 AC-DC Converter

Input 85Vac~265Vac, Output 24Vdc/12.5A, Full-Brick Series

Output Over Voltage Protection

The switching-off type over voltage protection feature is used to protect the converter, when output voltage exceeds 115% to 140% of the rated output voltage (the set point is between 115%-140%, there is the difference based on the specific parameters, but not beyond the range), the output voltage will shut down. When the converter internal detection circuit detect abnormal signals disappear the output will recovery.

EMC Consideration

Recommendation circuit for EMI Conducted emission、Fast transient/burst immunity、Surge immunity.

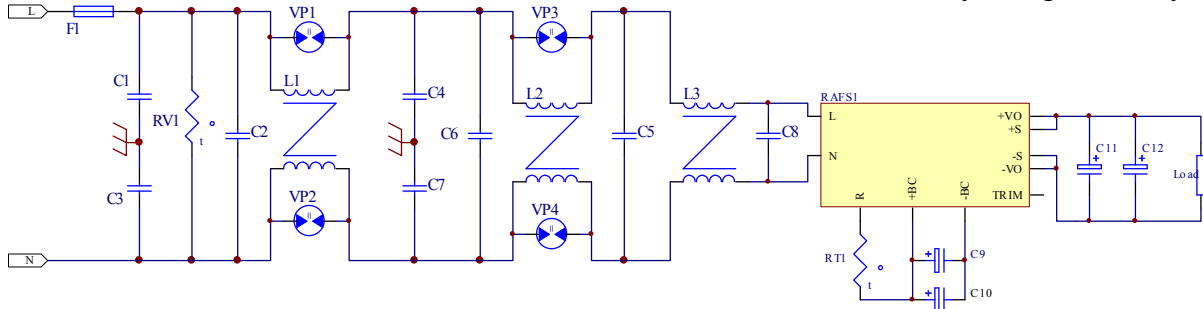

Part No.	Components	Part No.	Components
F1	Fuse:12A	L1,L2,L3	Common mode inductances: >5mH
RV1	471KD14	C2,C6,C5,C8	Safety and film CAPS: 0.68uF
VP1,VP2,VP3,VP4	2RM230L-8	C11,C12	Solid electrolytic CAPS: 220uF/35V
C1,C3,C4,C7	Y-CAPS:1nF/400VA	RT1	Thermistor: 5-10Ω/>3W
C9,C10	E-CAPS:220uF/450V	-	-

Safety Consideration

The converter, as one component for the end user, should be installed into the equipment, and all the safety considerations are achieved under certain condition. It is required to meet safety requirements in system design for the user. The primary to secondary is basic insulation to EN60950.The maximum operating temperature for PCB is 150 °C , conforming to CLASSE.

To avoid fire and be protected when short circuit occurred, it is recommended that a fast blow fuse with rating 2.5-3 times of converter continuous input peak current is used in series at the input terminal.(Inrush current suppression circuit is required for greater filter capacitance at input terminal, or it will result in the misoperation of the fuse).

Product Installation

The product can be installed in user board, suggest using M3 screw to fix the products in user board, in order to enhance the bearing ability when impactive and vibration coming. Note that,when you hammer the product using screws, this product shall be first fixed, again a needle pin welding, prevent strain soldered dot. Moreover the biggest torque of fastening screw cannot exceed 0.6 N.m,otherwise it will likely damage. the structural related to studs.

Metal surface of this product structured by aluminum PCB which has good thermal conductivity , mapping the overburden with heat conduction conlents or thermal gaskets, then install proper radiator.

Proper radiator and flows through radiator wind will greatly enhance products cooling capacity. when you install radiator ,you should be paid attention to the length of the bolt, ensure that has no relevant relatives with the screws fixed on PCB.

RAFS300-220W24 AC-DC Converter**Input 85Vac~265Vac, Output 24Vdc/12.5A, Full-Brick Series**

ESD Control

The converters are processed and manufactured in an ESD controlled environment and supplied in conductive packaging to prevent ESD damage from occurring before or during shipping. It is essential that they are unpacked and handled using an ESD control procedures. Failure to do so affects the lifetime of the converter.

Delivery Package Information

Package material is multiple wall corrugated ,internal material is anti-static foam ,it's surface resistance is from $10^5 \Omega$ to $10^{12} \Omega$. Tray capacity: 2×3=6 PCS/box ,Tray weight: 1.29kg;Carton capacity: 6×8=48PCS, Carton weight:11.0kg.

Quality Statement

The converters are manufactured in accordance with ISO 9001 system requirements, in compliant with EN50155, and are monitored 100% by auto-testing system, 100% burn in.

The warranty for the converters is 5-year.

Contact Information

*Anhui Hesion Trading Co.,Ltd.
& Beijing Yihongtai Technology Dev.Co.,Ltd*

TEL: +86-551-65369069,65369067

Email: alecz@ahhesion.com

Backup:alecz@126.com

www.ahhesionpower.com